

## Models

**Size range: 2" ~ 24"**  
Larger sizes available.



**CV 46-CS**  
(carbon steel)

**CV 46-SS**  
(stainless steel)

## Features

### COST EFFICIENT DESIGN

Low weight and short laying length produce savings in initial cost, space requirements, and installation when compared to full-body, swing-type check valves.

### MINIMAL HEAD LOSS

Contour of body provides a short and straight flow path that generates very little turbulence. Additionally, the spring-loaded discs are designed with very low cracking pressure which reduces the amount of energy required to open the valve.

### QUICK CLOSURE TO REDUCE WATER HAMMER

Shut-off is achieved via the fully automatic, spring-assisted discs that close near zero flow velocity. The light weight, split disc design creates a positive shut-off prior to flow reversal and helps to keep slamming and surges to a minimum.

### DESIGNED FOR LONG SERVICE LIFE

The spring and discs are designed to allow the discs to lift linearly before pivoting to avoid the disc heel from scrubbing the sealing surface. Also, discs are equipped with cast-in shock bumpers that help to reduce wear and tear on internal components.

### FUGITIVE EMISSION DESIGN

The retainer-less body design eliminates potential leak paths to the environment so there are no body emissions.

### RESILIENT AND METAL SEATS

Board, lapped sealing surface (metal) meets or exceeds API 598 test requirements. Resilient seats (viton/buna) ensure a bubble tight seal.

## Applications

### MARKETS:

Water & wastewater, pulp & paper, chemical & petrochemical, power, petroleum and oil & gas.

### BUNA-N PROPERTIES:

Most widely used elastomer. Good for most petroleum oils and fluids, silicone greases and oils, and cold water. excellent compression set, tear, and abrasion resistance. Poor weather resistance and moderate heat resistance. Not recommended for severe ozone-resistant applications.

### VITON PROPERTIES:

Offers a broad range of chemical resistance and excellent heat resistance. Good mechanical properties and compression set resistance. Often used in applications where nothing else will work. Fair low temperature resistance and limited hot-water resistance and shrinkage.

## Technical

<b>PRESSURE/ TEMPERATURE RATING (1)</b> CS - ASTM A216 GR. WCB - CLASS 600
WOG (Non-shock): 1480 PSI @ 100 °F
<b>PRESSURE/ TEMPERATURE RATING</b> SS - ASTM A351 GR. CF8M - CLASS 600
WOG (Non-shock): 1440 PSI @ 100 °F
<b>SEAT MATERIAL TEMPERATURE RANGE</b>
METAL: -325 ~ 1500 °F VITON: -40 ~ 400 °F BUNA-N: -20 ~ 250 °F
<b>SPRING MATERIAL TEMPERATURE MAXIMUM</b>
INCONEL X-750: 1000 °F

1. The above listed temperatures are theoretical and may vary during actual operating conditions.

The above data represents common market and service applications. No representation or guarantee, expressed or implied, is given due to the numerous variations of concentrations, temperatures and flow conditions that may occur during actual service.

# CV 46 - Check valve - Wafer type

Dual Disc - ANSI Class 600 - Carbon and Stainless Steel

BILL OF MATERIALS <sup>(1)</sup>			
No.	PART	CV 46-CS	CV 46-SS
1	Body	Carbon Steel <sup>(4)</sup> A216 Gr. WCB	Stainless Steel A351 Gr. CF8M
2	Seat	Metal <sup>(5)</sup> , Buna-N	Metal, Viton
3	Disc <sup>(2)</sup>	Stainless Steel A351 Gr. CF8M	Stainless Steel A351 Gr. CF8M
4	Spring <sup>(2)</sup>	Inconel X-750	Inconel X-750
5	Shaft/Stop Pin	Stainless Steel A276 Gr. 316	Stainless Steel A276 Gr. 316
6	Pin Cap <sup>(3)</sup>	Stainless Steel A276 Gr. 316	Stainless Steel A276 Gr. 316

1. Equivalent or better materials may be substituted at the manufacturer's discretion.
2. Denotes recommended spare parts.
3. Pin Cap is only on sizes 6" through 24".
4. Carbon Steel bodies are epoxy painted.
5. Metal seat has stainless steel inlay.

REFERENCED STANDARDS & CODES	
CODE	DESCRIPTION
ANSI/API 594	Check Valve Design and Manufacture
API 598	Valve Inspection and Testing
API 6D	Pipeline Valves

Exploded View

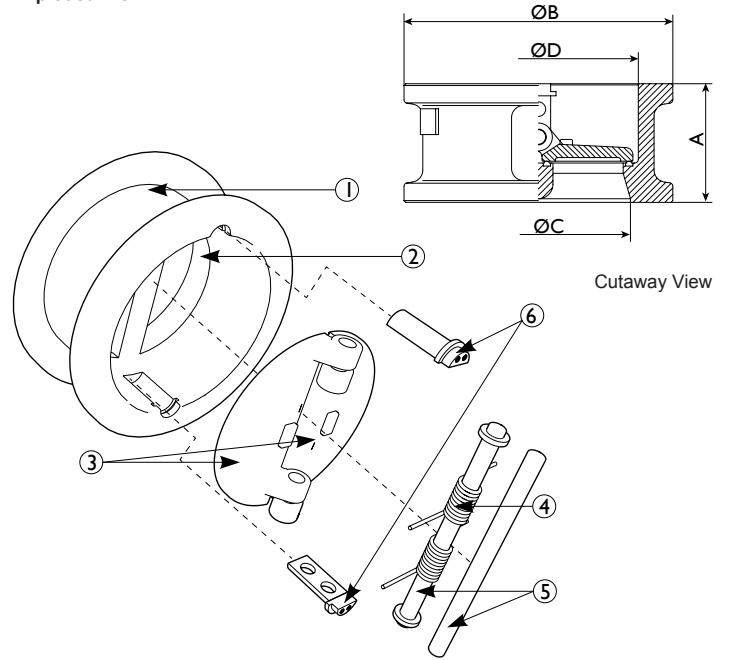

Illustrations are representative of sizes 6" through 24". Please ask for certified drawings when required.

DIMENSIONS AND PERFORMANCE DATA <sup>(1)</sup>															
SIZE	in	2	2 1/2	3	4	5	6	8	10	12	14	16	18	20	24
	mm	50	65	80	100	125	150	200	250	300	350	400	450	500	600
A DIMENSION <sup>(2)</sup> FACE TO FACE	in	2.375	2.625	2.875	3.125	4.125	5.375	6.50	8.375	9.00	10.75	12.00	14.25	14.50	17.25
	mm	60	67	73	79	105	136	165	213	229	273	305	362	368	438
ØB DIMENSION OVERALL DIAMETER	in	4.312	5.062	5.812	7.50	9.437	10.375	12.50	15.687	17.937	19.312	22.125	24.00	26.75	30.937
	mm	110	128	147	191	240	264	318	398	455	490	562	610	680	786
ØC DIMENSION INLET DIAMETER	in	2.00	2.562	3.00	4.00	5.00	6.00	7.875	9.843	11.812	13.187	15.156	17.125	19.187	23.031
	mm	51	65	76	102	127	152	200	250	300	335	385	435	487	585
ØD DIMENSION OUTLET DIAMETER	in	2.187	2.687	3.25	4.25	5.125	6.50	8.25	10.062	11.812	13.187	15.156	17.125	19.187	23.031
	mm	55	68	82	108	130	165	210	255	300	335	385	435	487	585
ASSEMBLED WEIGHT	lb	6	13	12	20	35	57	109	207	300	420	627	820	1015	1690
	kg	3	6	5	9	16	26	49	94	136	191	284	372	460	767
Flow Coefficient	C <sub>v</sub>	45	95	140	200	400	580	1350	1850	2500	4800	5520	7500	10300	11100
Cracking Pressure <sup>(3)</sup>	psi	≤ .25	≤ .25	≤ .25	≤ .25	≤ .25	≤ .25	≤ .25	≤ .25	≤ .25	≤ .25	≤ .25	≤ .25	≤ .25	≤ .25

1. Dimensions and weights are for reference only. When required, request certified drawings.
2. Face to face values have a tolerance of ±0.06 in (±2.0 mm) for sizes 10" and lower and a tolerance of ±0.12 in (±3.0 mm) for sizes 12" and larger.
3. Cracking pressure is for horizontal installations only. For vertical installations, please consult factory.

## PRESSURE - TEMPERATURE RATINGS <sup>(1)</sup>

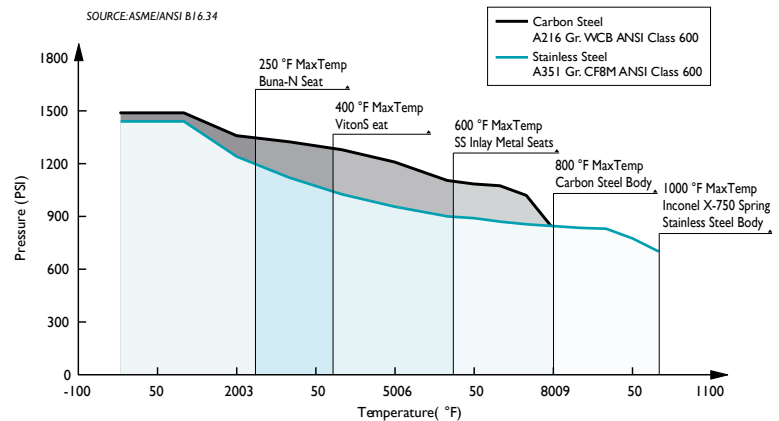

1. The above chart displays the pressure-temperature ratings for the valve's body material per ASME B16.34-1996. Max temperature limits have been added for seat and spring materials.

	PRESSURE	TEMPERATURE	RATING
<b>ANSI CLASS 600</b>	<b>A216 Gr. WCB</b>	<b>A351 Gr. CF8M</b>	
WOG (Non-shock):	1480 PSI @ 100 °F	1440 PSI @ 100 °F	

SEAT AND SPRING TEMPERATURE RATING			
Seat Material	Range	Spring Material	Max
VITON:	-40 ~ 400 °F	INCONEL X-750:	1000 °F
BUNA-N:	-20 ~ 250 °F		
METAL:	-325 ~ 1500 °F		

### Additional Design & Technical Notes:

- The CV 46 has a fugitive emission design. This retainer-less body design eliminates potential leak paths to the environment so there are no body emissions.

Titan FCI makes every effort to ensure the information presented on our literature accurately reflects exact product specifications. However, as product changes occur, there may be short-term differences between actual product specifications and the information contained within our literature. Titan FCI reserves the right to make design and specification changes to improve our products without prior notification. When required, request certified drawings.