

### 1. Pressure Ranges

2 bar(29 psig) to 8 bar(116 psig) double acting  
3 bar(44 psig) to 8 bar(116 psig) spring return

### 2. Temperature Ranges

\*Std.(NBR O-rings): -20°C(-4°F) to +80°C(+176°F)  
\*Lower Temp. (HNBR O-rings):-40°C(-40°F) to +80°C(+176°F) •  
\*High Temp. (Viton O-rings): -15°C(+5°F) to +150°C(+300°F) •

Note: Special grease is required for low and high temperature service condition.

### 3. Wide Range Available

The actuator range consists of 14 sizes, with torques from 9Nm(80in.lbs) to 3,920Nm (34,660in.lbs) at 6 bar (87 psig) air supply.

### 4. Operating Media

Filtered dry or lubricated air for non-corrosive gas, water or light hydraulic oil. The maximum particle size must not exceed 30 microns.

### 5. Stroke Adjustment

0°and 90° with standard adjustment  $\pm 5^\circ$ .



### 6. Lubrication

All moving parts are factory lubricated for entire life cycle of actuator.

### 7. Construction

Twin piston rack and pinion actuator design, suitable for indoor and outdoor installation.

### 8. Connections

Bottom drilling complies with ISO 5211/DIN 3337 to match valve. Interface for solenoid valve, shaft top end and top drilling for assembling accessories are in accordance with VDI/VDE-3845, NAMUR standard.

### 9. Inspection

Every actuator is hydraulically tested, certified and guaranteed for a minimum of 1 million cycles.

## Pneumatic Actuator - Features

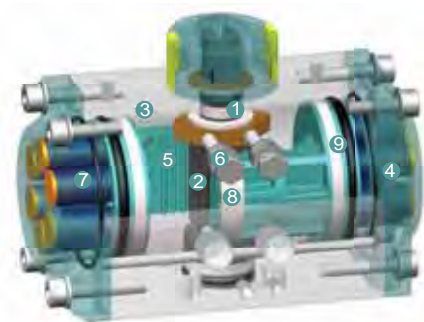

### 1. Indicator

A position indicator with Namur mounting is standard on all Nk-Series pneumatic actuators for mounting accessories.

### 2. Pinion

The hardened alloy steel pinion is precision ground and Nickel plated (over 15um) in order to reduce friction, provide maximum wear resistance. Full conformance with the newest standards of ISO5211 & DIN3337. The dimensions can be customized and as options, stainless steel and aluminium alloy are also available.

### 3. Actuator Body

The aluminum extrusion is hard anodized(over 30um) to protect against wear and corrosion while reducing piston friction to the absolute minimum. Other options such as Nickel, Ceramic, PTFE, Polyester coated are available.

### 4. End Caps

Epoxy coated(over 80um) die cast aluminum end caps provide maximum resistance against potentially corrosive elements. Other treatments such as Nickel, Ceramic, PTFE, Polyester coated are available.

### 5. Pistons

The precisely-balanced and hard anodized treatment (over 30um)die cast aluminum pistons are fitted with high quality rings and guides. The twin rack and piston design creates a constant torque output on all actuators.

### 6. Travel Adjustment

The standard adjustment is  $\pm 5^\circ$ in both the open and closed positions through easily accessible external adjustment bolts.

### 7. High Performance Springs

The high tensile steel springs are coated with Epoxy coated for corrosion resistance and longer service. The pre-loaded springs can be safely & rapidly disassembled.

### 8. Bearings & Guides

The highly durable compound material provides high trust stability with minimum friction and long life.

### 9. O-Rings

NBR O-rings provide trouble-free operation at standard temperature ranges. Viton and HNBR O-rings are available for high or low temperature applications.

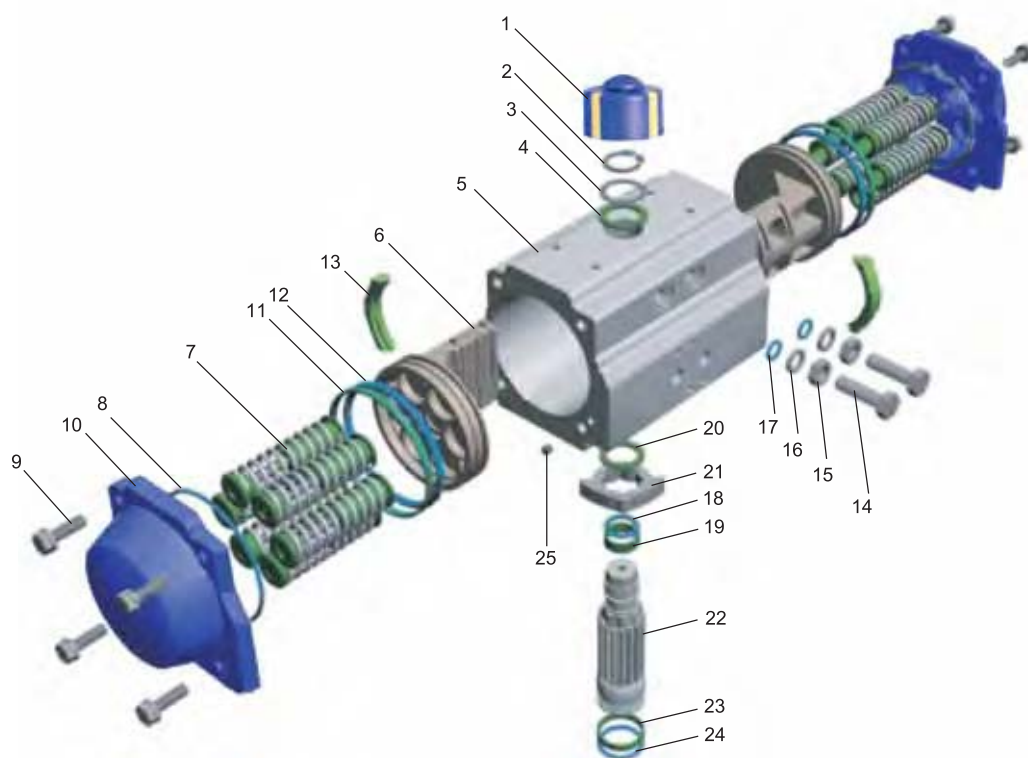

Item	Description	Material	Protection	Q'ty	Optional
1	Indicator	Plastic	••	1	
2	Spring Clip	Stainless Steel	••	1	••
3	Thrust Washer(Pinion)	Stainless Steel	••	1	••
4	Thrust Bearing(Pinion)	Nylon 66	••	1	••
5	Actuator Body	Extruded Alluminum Alloy	Hard Anodized(over 30um)	1	↓Nickel or PTFE coated
6	Piston	Die Cast Aluminum Alloy	Hard Anodized(over 30um)	2	
7	Spring(Cartridge)	High Performance Spring Steel	Epoxy Coated	0-12	••
8*	End Cap Seals	NBR	••	2	Viton / HNBR
9	End Cap Bolts	Stainless Steel	••	8	••
10	End Cap	Die Cast Aluminum	Epoxy Coated(over 80um)	2	↓Nickel or PTFE coated
11*	Piston Bearing	Nylon 66	••	2	••
12*	Piston Seal	NBR	••	2	Viton / HNBR
13*	Piston Guide	Nylon 66	••	2	••
14	Stroke Bolt	Stainless Steel	••	2	••
15	Stroke Bolt Retaining Nut	Stainless Steel	••	2	••
16	Stroke Bolt Washer	Stainless Steel	••	2	••
17*	Stroke Bolt O-Ring	NBR	••	2	Viton / HNBR
18*	O-Ring(Top Pinion)	NBR	••	1	Viton / HNBR
19*	Bearing(Top Pinion)	Nylon 66	••	1	••
20*	Thrust Bearing(Pinion)	Nylon 66	••	1	••
21	Stroke Cam	Stainless Steel	••	1	••
22	Pinion	Alloy Steel	Nickel Plated(over 15um)	1	S.S. or Alu.Alloy
23*	Bearing(Lower Pinion)	Nylon 66	••	1	••
24*	O-Ring(Lower Pinion)	NBR	••	1	Viton / HNBR
25*	Plug	NBR	••	2	Viton / HNBR

••Note: Recommended spare parts for maintenance.



Sizing example of Nk-Series double acting actuator:  
Valve torque 100Nm plus 20% safety factor= 120Nm. Minimum operating pressure 6bar(87psig). By reading down the 6bar(87 psig) column the figure below 120Nm is 135.0Nm, The model number shown in the left hand column is therefore NKD-092.

**The operating principle of double acting actuator**

CCW-counter-clockwise

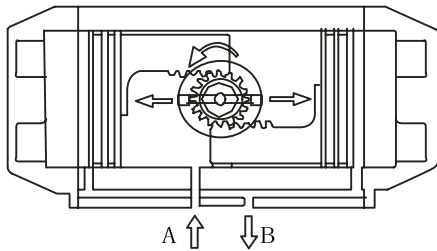

Air to port A forces the pistons outwards, causing the piston to turn counter-clockwise while air is being exhausted from port B.

CW-clockwise

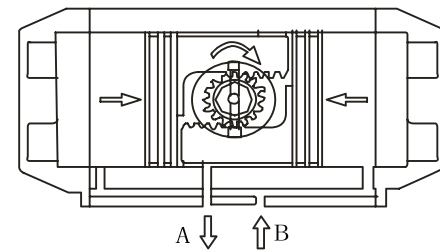

Air to port B forces the pistons inwards, causing the piston to turn clockwise while air is being exhausted from port A.

**Torque Table of Double Acting Actuator**

Unit : Nm

Model	Air Supply Pressure(unit:bar)							
	3.0	4.0	4.5	5.0	5.5	6.0	7.0	8.0
Output Torque(Nm)								
NKD-032	4.6	6.1	6.9	7.6	8.4	9.2	10.7	12.2
NKD-040	7.0	10.0	11.0	12.0	13.0	14.0	17.0	19.0
NKD-052	12.0	16.0	18.0	20.0	21.9	23.9	27.9	31.9
NKD-063	21.9	29.2	32.8	36.5	40.1	43.8	51.1	58.4
NKD-075	30.1	40.1	45.1	50.2	55.2	60.2	70.2	80.3
NKD-083	47.0	62.7	70.5	78.4	86.2	94.1	109.7	125.4
NKD-092	67.7	90.3	101.6	112.9	124.1	135.4	158.0	180.6
NKD-105	99	132	149	165	182	198	231	265
NKD-125	151	201	226	251	276	301	351	401
NKD-140	257	342	385	428	470	513	599	684
NKD-160	399	532	599	665	732	798	931	1064
NKD-190	638	851	958	1064	1170	1277	1490	1702
NKD-210	798	1064	1197	1330	1463	1596	1862	2128
NKD-240	1154	1539	1731	1924	2116	2309	2693	3078
NKD-270	1755	2339	2632	2924	3217	3509	4094	4679
NKD-300	2289	3052	3434	3815	4197	4578	5341	6104
NKD-350	3427	4570	5141	5712	6283	6854	7997	9139
NKD-400	4884	6512	7326	8140	8954	9768	11396	13024

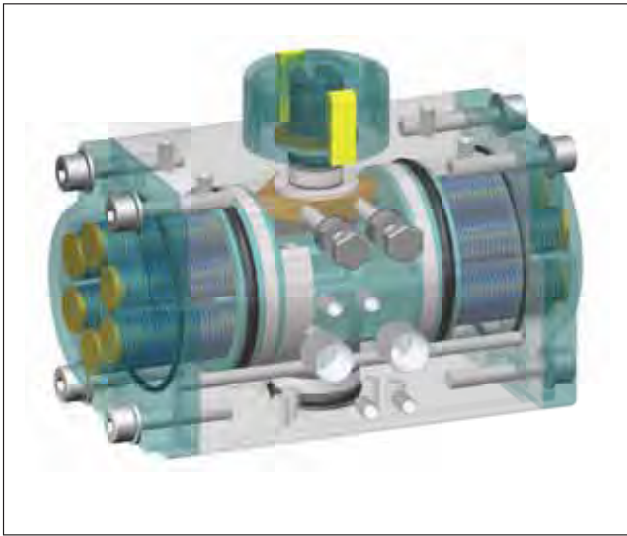

Sizing example of Nk-Series spring return actuator:

Spring to close when air fails(air to open):

Valve torque 60Nm plus 20% safety factor = 72Nm. Minimum operating pressure: 6bar(87psig). The spring return Nk-Series actuator selected is NKS-105-12.The NKS-105-12 has the following output torques:

- 1.air torque 0°(valve close) = 122.5Nm > 72Nm
- 2.air torque 90°(valve open) = 80.6Nm
- 3.spring torque 90°(valve open) = 118.1Nm
- 4.spring torque 0°(valve close) = 75.9Nm > 72Nm

**The operating principle of single acting spring return actuator**

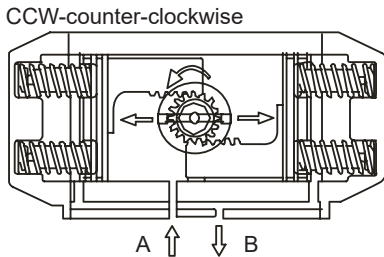

Air to port A forces the pistons outwards, causing the springs to compress. The pinion turns counter-clockwise while air is being exhausted through port B.

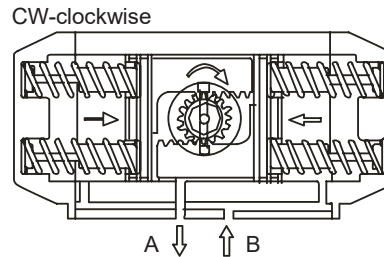

Loss of air pressure through port A allows the stored energy in the springs to force the pistons inwards. The pinion turns clockwise while air is being exhausted through port A.

**Mounting Variations**

CCW-counter-clockwise

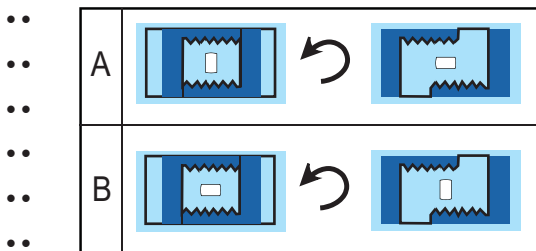

CW-clockwise

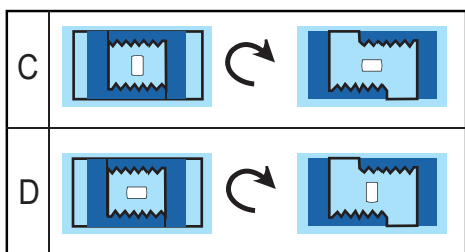

**Spring Arrangement**

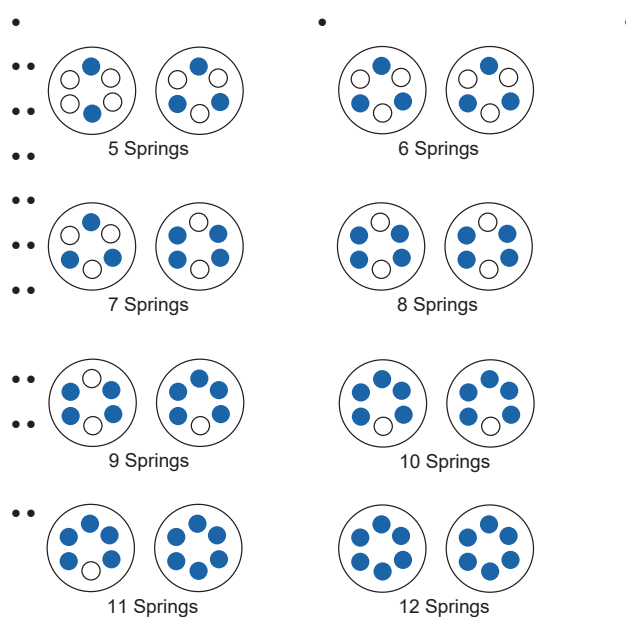

unit:Nm

Model	Spring Set	Spring Torque (Nm)		Air Supply Pressure ( Unit:bar)													
				2.5		3.0		4.0		5.0		6.0		7.0		8.0	
				Air Torque Output(Nm)													
	0°	90°	0°	90°	0°	90°	0°	90°	0°	90°	0°	90°	0°	90°	0°	90°	
NKS-052	5	4.3	6.2	5.7	3.8	7.6	5.7	---	---	---	---	---	---	---	---	---	---
	6	5.0	7.4	4.9	2.5	6.9	4.5	10.9	8.5	---	---	---	---	---	---	---	---
	7	5.9	8.6	4.0	1.3	6.0	3.3	9.8	7.3	14.0	10.4	---	---	---	---	---	---
	8	6.7	9.9	---	---	5.2	2.0	9.2	6.0	13.2	9.1	17.2	14.1	---	---	---	---
	9	7.6	11.1	---	---	4.3	0.8	8.3	4.8	12.3	7.9	16.3	12.8	20.3	16.8	---	---
	10	8.5	12.4	---	---	---	---	7.4	3.6	11.5	6.7	15.5	11.6	19.5	15.6	---	---
	11	9.3	13.6	---	---	---	---	6.6	2.3	10.6	5.4	14.6	10.4	18.6	14.3	22.6	18.3
12	10.2	14.8	---	---	---	---	---	---	9.7	4.2	13.8	9.1	17.8	12.2	21.8	17.1	
NKS-063	5	6.8	10.4	14.1	7.7	15.0	11.4	22.3	14.9	---	---	---	---	---	---	---	---
	6	8.2	12.5	10.1	5.7	13.6	9.3	20.9	16.6	28.3	23.9	---	---	---	---	---	---
	7	9.6	14.6	8.6	3.6	12.5	7.2	19.5	14.5	26.8	21.9	---	---	---	---	---	---
	8	10.9	16.7	---	---	10.9	5.1	18.2	12.4	25.5	19.8	32.8	27.0	40.1	34.3	---	---
	9	12.3	18.8	---	---	---	---	16.8	10.4	24.1	17.7	31.4	24.9	38.7	32.2	---	---
	10	13.7	20.9	---	---	---	---	11.4	8.2	22.8	15.6	30.0	22.8	37.3	30.1	44.7	37.4
	11	15.0	22.9	---	---	---	---	---	---	21.5	13.5	28.7	20.7	36.0	28.0	43.3	35.3
12	16.4	25.0	---	---	---	---	---	---	20.0	11.4	27.3	18.6	34.6	25.9	41.9	33.3	
NKS-075	5	10.5	14.5	14.5	10.6	19.4	15.5	29.5	25.7	---	---	---	---	---	---	---	---
	6	12.7	17.4	12.4	7.6	17.3	12.6	27.4	22.7	37.5	32.8	---	---	---	---	---	---
	7	14.8	20.3	10.4	4.8	15.2	9.7	25.3	19.9	35.4	29.9	---	---	---	---	---	---
	8	16.9	23.2	---	---	13.1	6.8	23.1	16.9	33.3	27.0	43.2	37.0	53.3	47.0	---	---
	9	19.0	26.1	---	---	---	---	21.0	14.1	31.2	24.1	41.1	34.1	51.2	44.2	---	---
	10	21.1	29.0	---	---	---	---	19.0	11.1	28.8	21.2	39.0	31.2	49.1	41.2	59.1	51.2
	11	23.2	31.9	---	---	---	---	---	---	27.0	18.3	37.0	28.3	47.0	38.4	57.0	48.4
12	25.3	34.7	---	---	---	---	---	---	24.9	15.4	34.9	25.4	44.9	35.4	54.9	45.4	
NKS-083	5	15.8	23.0	23.7	16.1	31.1	24.0	46.8	37.9	---	---	---	---	---	---	---	---
	6	19.0	27.6	20.1	11.5	28.0	19.3	43.7	35.1	59.4	50.7	---	---	---	---	---	---
	7	22.1	32.2	17.0	6.9	24.8	14.8	40.5	30.5	56.2	46.2	---	---	---	---	---	---
	8	25.3	36.8	---	---	21.7	10.1	37.4	25.8	53.1	41.5	68.8	57.2	84.5	72.9	---	---
	9	28.5	41.4	---	---	---	---	34.2	21.3	49.9	37.0	65.6	52.6	81.2	68.3	---	---
	10	31.6	46.0	---	---	---	---	31.0	16.6	46.7	32.3	62.4	48.0	78.1	63.7	93.8	79.3
	11	34.8	50.6	---	---	---	---	---	---	43.6	27.7	59.3	43.4	75.0	59.1	90.6	74.8
12	38.0	55.2	---	---	---	---	---	---	40.4	23.2	56.1	38.9	71.7	54.5	87.4	70.2	
NKS-092	5	23.3	34.4	33.1	22.0	44.2	33.2	66.8	55.9	---	---	---	---	---	---	---	---
	6	28.0	41.2	28.4	15.2	39.6	26.4	62.2	49.0	84.8	71.6	---	---	---	---	---	---
	7	32.7	48.1	23.8	8.2	34.9	19.4	57.5	42.1	80.2	64.7	---	---	---	---	---	---
	8	37.3	55.0	---	---	31.3	12.6	52.9	35.2	75.5	57.9	98.1	80.5	120.7	103.0	---	---
	9	42.0	61.9	---	---	---	---	48.2	28.4	70.9	51.0	93.5	73.6	116.0	96.1	---	---
	10	46.7	68.7	---	---	---	---	43.6	21.5	66.2	44.1	88.8	66.7	111.3	89.2	134.0	111.8
	11	51.4	75.6	---	---	---	---	---	---	61.5	37.2	84.1	59.9	106.6	82.4	129.2	105.0
12	56.0	82.5	---	---	---	---	---	---	56.8	30.4	79.4	53.0	101.9	75.5	124.5	98.1	
NKS-105	5	31.6	49.2	51.0	33.4	67.5	49.9	100.6	83.0	---	---	---	---	---	---	---	---
	6	38.0	59.1	44.7	23.5	61.1	40.0	94.2	73.2	127.3	106.2	---	---	---	---	---	---
	7	44.3	68.9	38.4	13.7	54.9	30.3	87.9	63.4	121.0	96.4	---	---	---	---	---	---
	8	50.6	78.7	---	---	48.5	20.4	81.6	53.5	114.7	86.5	147.7	119.6	180.8	152.7	---	---
	9	56.9	88.6	---	---	---	---	75.3	43.7	108.4	76.8	141.5	109.8	174.5	142.9	---	---
	10	63.3	98.4	---	---	---	---	68.9	33.4	102.0	66.5	135.1	99.6	168.2	132.6	201.2	165.7
	11	69.6	108.3	---	---	---	---	---	---	95.7	57.0	128.7	90.1	161.8	123.1	194.8	156.2
12	75.9	118.1	---	---	---	---	---	---	89.4	47.5	122.5	80.6	155.5	113.6	188.6	146.7	
NKS-125	5	52	79	73	47	98	72	148	122	---	---	---	---	---	---	---	---
	6	63	94	63	31	88	56	138	107	188	157	---	---	---	---	---	---
	7	73	110	52	15	77	40	127	90	178	141	---	---	---	---	---	---
	8	84	125	---	---	67	25	117	75	167	125	217	176	268	226	---	---
	9	94	141	---	---	---	---	107	59	157	109	207	159	257	210	---	---
	10	105	157	---	---	---	---	96	44	146	94	196	144	247	194	297	245
	11	115	173	---	---	---	---	---	---	136	78	186	128	236	178	286	228
12	125	188	---	---	---	---	---	---	125	63	176	113	226	163	276	213	
NKS-140	5	86	129	128	85	171	127	256	213	---	---	---	---	---	---	---	---
	6	103	155	111	59	154	102	239	187	325	273	---	---	---	---	---	---
	7	120	181	94	33	137	76	222	162	308	247	---	---	---	---	---	---
	8	137	206	---	---	120	50	205	136	291	221	376	307	462	392	---	---
	9	155	232	---	---	---	---	187	110	273	196	358	281	444	367	---	---
	10	172	258	---	---	---	---	170	84	256	169	341	255	427	340	512	426
	11	189	284	---	---	---	---	---	---	238	143	324	229	409	314	495	400
12	206	310	---	---	---	---	---	---	221	118	307	203	392	289	478	374	

unit:Nm

Model	Spring Set	Spring Torque (Nm)		Air Supply Pressure ( Unit:bar)													
				2.5		3.0		4.0		5.0		6.0		7.0		8.0	
				Air Torque Output(Nm)													
		0°	90°	0°	90°	0°	90°	0°	90°	0°	90°	0°	90°	0°	90°	0°	90°
NKS-160	5	140	208	193	124	259	191	392	324	---	---	---	---	---	---	---	---
	6	168	250	165	83	232	149	365	282	498	415	---	---	---	---	---	---
	7	196	292	137	41	203	107	336	240	469	373	---	---	---	---	---	---
	8	223	333	---	---	176	66	309	199	442	332	575	465	708	598	---	---
	9	251	375	---	---	---	---	280	157	413	290	546	423	679	556	---	---
	10	279	417	---	---	---	---	253	115	386	248	519	381	652	514	785	647
	11	307	458	---	---	---	---	---	---	358	207	491	340	624	473	757	606
	12	335	500	---	---	---	---	---	---	330	165	463	298	596	431	729	564
NKS-190	5	200	309	332	222	438	329	651	542	---	---	---	---	---	---	---	---
	6	240	371	292	161	398	267	611	480	824	693	---	---	---	---	---	---
	7	280	433	252	99	358	205	571	418	784	631	---	---	---	---	---	---
	8	320	495	---	---	318	143	531	356	744	569	957	782	1169	995	---	---
	9	360	557	---	---	---	---	491	295	704	507	917	720	1130	933	---	---
	10	400	618	---	---	---	---	451	233	664	446	877	658	1090	871	1302	1084
	11	440	680	---	---	---	---	---	---	624	384	837	597	1050	809	1263	1022
	12	480	742	---	---	---	---	---	---	584	322	797	535	1010	748	1223	960
NKS-210	5	275	380	390	285	523	418	789	684	---	---	---	---	---	---	---	---
	6	330	456	335	209	468	342	734	608	1000	874	---	---	---	---	---	---
	7	385	532	280	133	413	266	679	532	945	798	---	---	---	---	---	---
	8	440	608	---	---	358	190	624	456	890	722	1156	988	1422	1254	---	---
	9	495	684	---	---	---	---	569	380	835	646	1101	912	1367	1178	---	---
	10	550	760	---	---	---	---	514	304	780	570	1046	836	1312	1102	1578	1368
	11	605	836	---	---	---	---	---	---	725	494	991	760	1257	1026	1523	1292
	12	660	912	---	---	---	---	---	---	670	418	936	684	1202	950	1468	1216
NKS-240	5	410	554	552	409	744	600	1129	985	---	---	---	---	---	---	---	---
	6	490	665	470	297	662	489	1047	874	1432	1259	---	---	---	---	---	---
	7	575	775	388	187	580	379	964	764	1349	1149	---	---	---	---	---	---
	8	656	886	---	---	498	268	883	653	1267	1037	1652	1422	2037	1807	---	---
	9	739	998	---	---	---	---	800	542	1185	926	1569	1311	1954	1696	---	---
	10	821	1108	---	---	---	---	718	431	1103	816	1488	1201	1872	1586	2257	1970
	11	903	1219	---	---	---	---	---	---	1021	705	1406	1090	1791	1471	2176	1859
	12	985	1330	---	---	---	---	---	---	939	594	1323	979	1708	1363	2093	1748
NKS-270	5	560	787	903	675	1195	968	1779	1552	---	---	---	---	---	---	---	---
	6	672	943	790	519	1083	811	1667	1396	2252	1981	---	---	---	---	---	---
	7	783	1101	679	361	972	654	1556	1238	2141	1823	---	---	---	---	---	---
	8	895	1258	---	---	860	479	1444	1081	2029	1666	2614	2252	3199	2836	---	---
	9	1007	1416	---	---	---	---	1332	923	1917	1509	2502	2094	3087	2678	---	---
	10	1119	1572	---	---	---	---	1220	767	1805	1352	2390	1937	2974	2521	3560	3107
	11	1231	1730	---	---	---	---	---	---	1693	1197	2278	1779	2862	2364	3448	2949
	12	1342	1887	---	---	---	---	---	---	1582	1037	2167	1623	2751	2207	3336	2792
NKS-300	5	730	1061	1097	729	---	---	---	---	---	---	---	---	---	---	---	---
	6	876	1273	935	494	1316	875	---	---	---	---	---	---	---	---	---	---
	7	1022	1485	772	258	1153	639	1916	1402	---	---	---	---	---	---	---	---
	8	1168	1697	---	---	991	403	1754	1166	2517	1929	---	---	---	---	---	---
	9	1314	1909	---	---	---	---	1592	930	2355	1693	3118	2456	---	---	---	---
	10	1460	2122	---	---	---	---	1430	695	2193	1458	2956	2221	3719	2984	4482	3747
	11	1606	2334	---	---	---	---	---	---	2030	1222	2793	1985	3556	2748	4319	3511
	12	1752	2546	---	---	---	---	---	---	1868	986	2631	1749	3394	2512	4157	3275
NKS-350	5	1173	1702	1553	964	---	---	---	---	---	---	---	---	---	---	---	---
	6	1408	2043	1292	586	1863	1157	---	---	---	---	---	---	---	---	---	---
	7	1642	2383	1031	208	1602	779	2745	1922	---	---	---	---	---	---	---	---
	8	1877	2724	---	---	1341	401	2484	1544	3626	2686	---	---	---	---	---	---
	9	2112	3064	---	---	---	---	2224	1165	3336	2307	4508	3449	---	---	---	---
	10	2346	3405	---	---	---	---	1963	787	3105	1929	4247	3071	5390	4214	6532	5356
	11	2581	3745	---	---	---	---	---	---	2844	1551	3986	2693	5129	3836	6271	4978
	12	2816	4086	---	---	---	---	---	---	2584	1172	3726	2314	4869	3457	6011	4599
NKS-400	5	---	---	---	---	---	---	---	---	---	---	---	---	---	---	---	---
	6	---	---	---	---	---	---	---	---	---	---	---	---	---	---	---	---
	7	1837	2880	2028	869	---	---	---	---	---	---	---	---	---	---	---	---
	8	2100	3292	1736	411	2550	1225	---	---	---	---	---	---	---	---	---	---
	9	2362	3703	---	---	2259	768	3887	2396	---	---	---	---	---	---	---	---
	10	2624	4115	---	---	1967	311	3595	1939	5223	3567	---	---	---	---	---	---
	11	2887	4526	---	---	---	---	3303	1482	4931	3110	6559	4738	---	---	---	---
	12	3149	4938	---	---	---	---	3012	1025	4640	2653	6268	4281	7895	5908	9523	7536

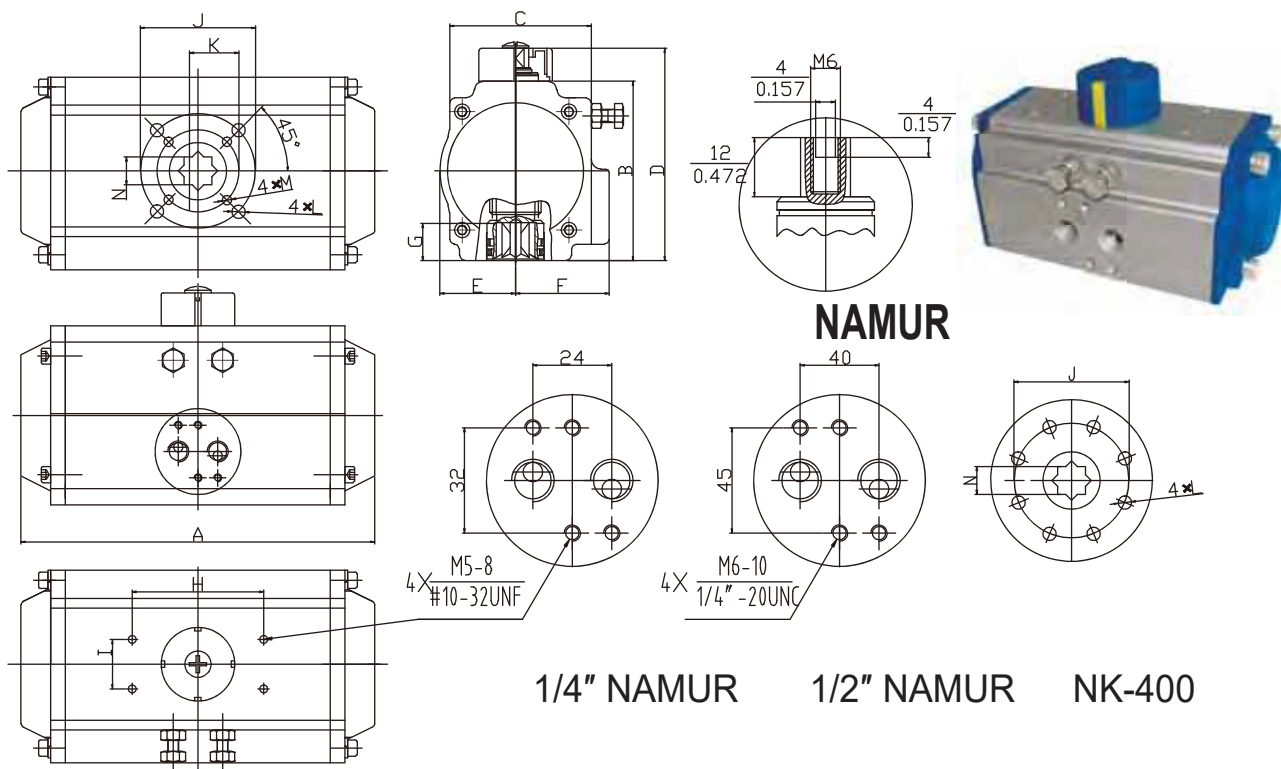

Dimension Table

Unit: mm  
inch

Model	A	B	C	D	E	F	G	H	I	N	J	K	L	M	Air Connection
NK-032	110	45	45	65	22.5	22.5	11	50	25	9	F03	---	M5*7.5	---	1/8"
	4.33	1.77	1.77	2.65	0.89	0.89	0.89	1.97	0.98	0.35			#10-24UNF		
NK-040	122	60	52	80	28.5	36.5	14	80	30	11	F05	F03	M6*10	M5*7.5	1/4"
	4.80	2.36	2.05	3.15	1.12	1.44	0.55	3.15	1.18	0.43			1/4"-20UNC	#10-24UNF	
NK-052	146	72	60	92	26	41.5	14	80	30	11	F05	F03	M6*10	M5*7.5	1/8" or 1/4"(std)
	5.74	2.83	2.36	3.62	1.02	16.33	0.55	3.15	1.18	0.43			1/4"-20UNC	#10-24UNF	
NK-063	169	88	69.5	108	33.5	47	17	80	30	14	F07	F05	M8*13	M6*10	1/8" or 1/4"(std)
	6.65	3.46	27.36	2.25	1.31	1.85	0.66	3.15	1.18	0.55			5/16"-20UNC	1/4"-20UNC	
NK-075	186	100	78	120	39	53	17	80	30	14	F07	F05	M8*13	M6*10	1/8" or 1/4"(std)
	7.32	3.93	3.07	4.72	1.53	2.08	0.66	3.15	1.18	0.55			5/16"-20UNC	1/4"-20UNC	
NK-083	210	109	86	129	40	57	20	80	30	17	F07	F05	M8*13	M6*10	1/8" or 1/4"(std)
	8.26	4.29	3.38	5.07	1.57	2.24	0.79	3.15	1.18	0.67			5/16"-20UNC	1/4"-20UNC	
NK-092	264	117	90.5	137	44.5	58.5	20	80	30	17	F07	F05	M8*13	M6*10	1/8" or 1/4"(std)
	10.39	4.6	3.56	5.39	1.75	2.3	0.79	3.15	1.18	0.67			5/16"-20UNC	1/4"-20UNC	
NK-105	272	133	104	153	52	64	26	80	30	22	F10	F07	M10*16	M8*13	1/4"
	10.7	5.23	4.09	6.02	2.04	2.51	1.02	3.15	1.18	0.87			3/8"-20UNC	5/16"-20UNC	
NK-125	302	155	120	185	60	74.5	25	130	30	22	F10	F07	M10*16	M8*13	1/4"
	11.88	6.1	4.72	7.28	2.36	2.93	0.98	5.11	1.18	0.87			3/8"-20UNC	5/16"-20UNC	
NK-140	398	172	125	202	65	77	30	130	30	27	F12	F10	M12*20	M10*16	1/4"
	15.66	6.77	4.92	7.95	2.55	3.03	1.18	5.11	1.18	1.06			1/2"-20UNC	3/8"-20UNC	
NK-160	456	197	142	227	74	87	30	130	30	27	F12	F10	M12*20	M10*16	1/4"
	17.95	7.75	5.59	8.93	2.91	3.42	1.18	5.11	1.18	1.06			1/2"-20UNC	3/8"-20UNC	
NK-190	534	230	172	260	86	103	40	130	30	36	F14	---	M16*20	---	1/4"
	21.02	9.05	6.77	10.23	3.38	4.05	1.57	5.11	1.18	1.42			5/8"-20UNC		
NK-210	536	255	194	285	97	113	43	130	30	36	F14	---	M16*20	---	1/4"
	21.1	10.03	7.63	1.12	3.81	4.44	1.69	5.11	1.18	1.42			5/8"-20UNC		
NK-240	612	290	230	320	115	130	50	130	30	46	F16	---	M20*25	---	1/4" or 3/8"(std)
	24.09	11.41	9.05	12.59	4.52	5.11	1.97	5.11	1.18	1.81			3/4"-20UNC		
NK-270	718	330	252	360	126	147	50	130	30	46	F16	---	M20*25	---	1/2"
	28.26	12.99	9.92	14.17	4.96	5.78	1.97	5.11	1.18	1.81			3/4"-20UNC		
NK-300	784	354	335	384	162	173	50	130	30	46	F16	---	M20*25	---	1/2"
	30.86	13.93	13.2	15.11	6.37	6.8	1.97	5.11	1.18	1.81			3/4"-20UNC		
NK-350	845	410	385	440	190	195	50	130	30	46	F16	F25	M20*25	---	1/2"
	33.26	16.14	15.15	17.32	7.48	7.67	1.97	5.11	1.18	1.81			3/4"-20UNC		
NK-400	956	466	520	496	260	260	60	130	30	55	F16	F25	M16*20	---	1/2"
	37.63	18.34	20.47	19.52	10.23	10.23	2.36	5.11	1.18	2.16			5/8"-20UNC		

\* Dimensions for reference only, subject to change.